

EDGE™ Series 4

High Capacity, Single Stage Regulators



The **EDGE** regulator offers the best pressure and flow delivery performance available in a single-stage regulator across a full range of cylinder pressures, even when inlet pressures are low.

Its compact design makes the regulator less vulnerable to damage in the work environment and the vent system is protected under the knob making it less exposed to weather elements and rainwater. The **SLAM™** (Shock Limitation and Absorption Mechanism) knob protects the regulator and cylinder valve in the event of a cylinder fall and can absorb more than 5,000 ft-lb of force.

- Highly durable colour-coded gauges are recessed and bonnet material is over twice the yield strength of brass.
- Robust seat gives optimum performance
- Consistent pressure and flow delivery
- High resistance to oxygen related fires
- Meets ISO 2503

Visit esab.com for more information.

Industry

- Shipbuilding
- Automotive
- Rail
- Fabrication
- Offshore
- Construction
- Maintenance/Repair

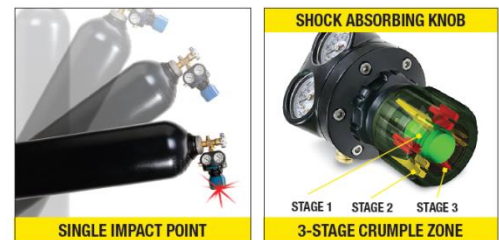

SLAM knob absorbs impact in the event of a cylinder fall

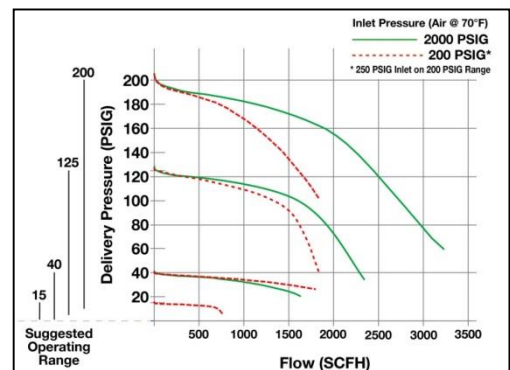

EDGE Series 4 Flow Data

Technical Data

Model	Gas Service	Max. Inlet Pressure	Outlet Pressure	Inlet & Outlet
ESS4-10B-W21.8 LH-EDGE HYDROGEN	Hydrogen	200 Bar	10 Bar	SS2238 Inlet, G3/8 LH outlet
ESS4-10B-DIN9 EDGE 4 Oxygen	Oxygen	200 Bar	10 Bar	DIN 9 Inlet, G 1/4 RH outlet
ESS4-10B-D54 EDGE 4 Nitrogen	Nitrogen	300 Bar	10 Bar	DIN 54 Inlet, G 1/4 RH outlet
ESS4-10B-DIN10 EDGE 4 Nitrogen	Nitrogen	200 Bar	10 Bar	DIN 10 Inlet, G 1/4 RH outlet
ESS4-1.5B-DIN3 EDGE 4 Acetylene	Acetylene	25 Bar	1.5 Bar	DIN 3 Inlet (Yoke), G 3/8 LH outlet
ESS4-4B-DIN1 EDGE 4 Propane	Propane	25 Bar	4 Bar	DIN 1 Inlet, G 3/8 LH outlet
ESS4-40-D54 EDGE 4 AR-CO ₂	Argon/CO ₂	300 Bar	40 lpm	DIN 54 Inlet, G 1/4 RH outlet
ESS4-40-DIN6 EDGE 4 AR-CO ₂	Argon/CO ₂	200 Bar	40 lpm	DIN 6 Inlet, G 1/4 RH outlet

Ordering Information

Model	Description	Part Number
ESS4-10B-W21.8 LH-EDGE HYDROGEN	Edge SS4 Single Stage Regulator Hydrogen	0700017625
ESS4-10B-DIN9 EDGE 4 Oxygen	10 Bar Single stage regulator, Oxygen, 200 Bar input	0700017437
ESS4-10B-D54 EDGE 4 Nitrogen	10 Bar Single stage regulator, Nitrogen, 300 Bar input	0700017439
ESS4-10B-DIN10 EDGE 4 Nitrogen	10 Bar Single stage regulator, Nitrogen, 200 Bar input	0700017440
ESS4-1.5B-DIN3 EDGE 4 Acetylene	1.5 Bar Single stage regulator, Acetylene, 25 Bar input	0700017442
ESS4-4B-DIN1 EDGE 4 Propane	4 Bar Single stage regulator, Propane, 25 Bar input	0700017444
ESS4-40-D54 EDGE 4 AR-CO ₂	40 lpm Single stage regulator, Argon/CO ₂ , 300 Bar input	0700017457
ESS4-40-DIN6 EDGE 4 AR-CO ₂	40 lpm Single stage regulator, Argon/CO ₂ , 200 Bar input	0700017454

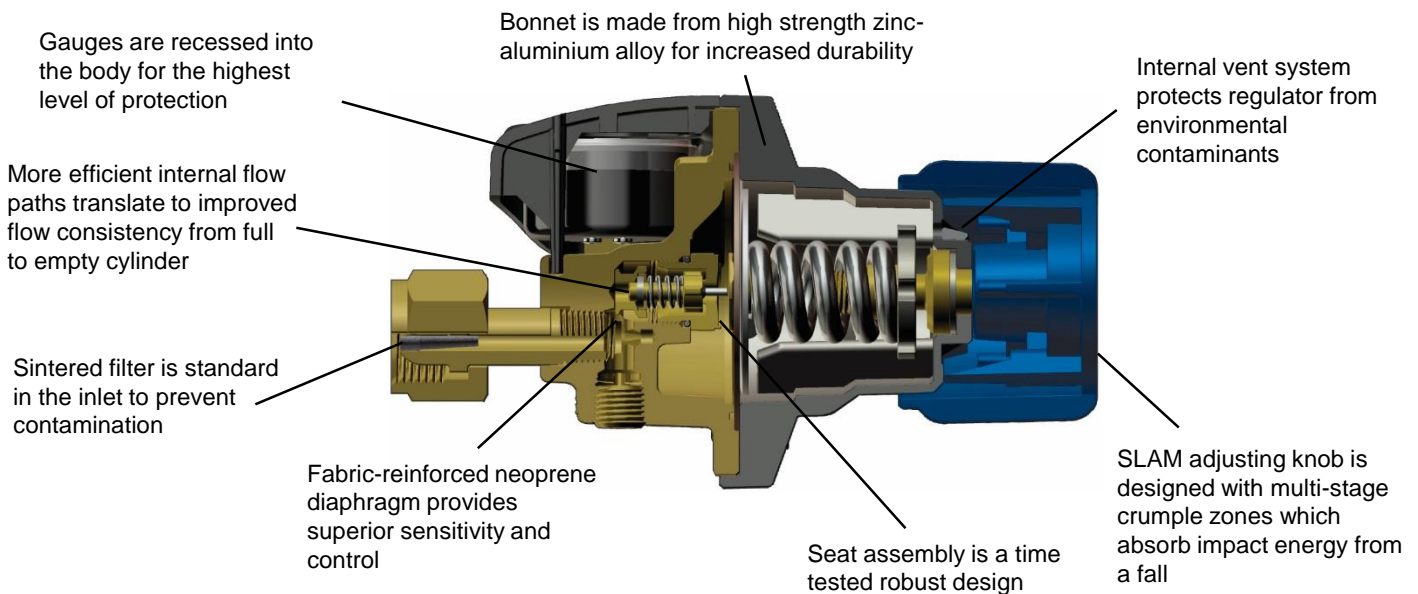

ESAB / esab.com

